



4 Inch (100mm) Submersible Pumps

Installation and Operation Manual

“SC” Series All Stainless Steel
“SD” Composite/Stainless Steel



General Information and Precautions

Submersible pumps are precision equipment designed for years of trouble free service, provided that they are properly installed and maintained. Refer to “Warnings & Specifications” at the back of this manual.

The pump package includes pump, motor, motor tail lead, and cable splicing kit on all units. A control box (which contains the start capacitor(s) and thermal overload relay) is shipped as standard equipment on all three wire, single phase units. The two wire, single phase units do not require a control box as the start capacitor and thermal overload is built into the motor. Magnetic starters, equipped with the correct quick trip thermal overloads, are required for three phase units. Properly grounded lightning arrestors are recommended on all installations that do not have built-in lightning protection in the motor.

WARNINGS:

1. All electrical connections must be performed by qualified personnel working in accordance with National and Local Electrical Codes. Failure to comply with these codes could result in serious injury or death from electrical shock, or cause serious damage to the pump unit.
2. The bore must be clean and straight. Submersible pumps are designed to allow the passage of a small amount of sand; however, pumping sand for a prolonged period will shorten the life of any pump.
3. The pump should be installed at least 3 metres (10 feet) above the bottom of the bore to prevent sediment from covering the motor, which could result in overheating and damage to the motor windings. Where possible, the pump should be installed at least 4.5 metres (15 feet) below the lowest pumping water level. A motor cooling shroud is recommended.
4. Never support the weight of the pump on the electrical cable. Support it with the rising main or an auxiliary rope during installation. Throughout installation, take care not to damage the insulation on the cable.

IMPORTANT
For future reference, record details of your pump unit here.

Date installed/...../.....

Submersible Pump

Model:	
Serial No:	
Q. m ³ /hr (@BEP)	
H.m (@BEP)	
P. kWHz
RPM.....	Max H..... m

A division of **tyco** Flow Control Pacific Pty Ltd

Instructions for Coupling Pump End Assembly to Motor (if not assembled)

The pump end is designed to be coupled to a 100mm electric submersible motor equipped with a NEMA flange and shaft protrusion. To assemble the pump and motor:

1. Make sure that the pump and motor rotors rotate freely.
2. Carefully clean the surfaces to be joined.
3. For motors with separate leads clean and dry any moisture from both the cavity on the motor and the rubber end of the electrical cable connection. Insert the cable connection (using no lubrication) and tighten with a torque wrench set at 27Nm (20 ft.lbs).
4. Align cable with cable protector and push the motor lead through the suction inlet and under the cable guard. Do not slacken nuts on pump straps (all stainless steel SC Series units).
5. Couple the pump to the motor making sure that the motor shaft freely enters the splined slot on pump coupling. A layer of waterproof grease should be applied to the coupling splines to help with this operation and to protect against wear caused by any abrasive particles remaining.
6. Tighten the four motor bolts with a torque wrench set at 18Nm (14 ft.lbs).

Pre-Installation Tests

Complete as many pre-installation tests as possible prior to taking the pump to the installation site.

1. Be careful not to damage the motor, pump, and motor lead. Visually inspect for possible damage. Check the lead for abrasions or cuts. Make certain the check valve operates freely.
2. Check the motor, pump, and control equipment to be certain they are matched. If using a three phase motor, check quick trip thermal overloads in the magnetic starter against motor requirements specified on the motor label.
3. Mount the pump end on the motor, if needed (see previous section). Splice the cable to the furnished lead with the supplied splice kit, following the splice kit instructions. Use only the size cable recommended in the Cable Selection Table (Page 6) to assure adequate voltage at the motor.



4. Remove cover from control box on magnetic starter. Do not connect line voltage at this time. Connect cable to control box. Make certain each lead is connected to the proper terminal as indicated in the instruction on the control box (also refer to the section on Wiring the Pump).
5. Submerge the pump in clean water in a test tank. Make certain that the water is at least five inches above the inlet screen.
6. Make certain mains isolation switch is off. Connect line from disconnect switch to control box. Turn on power at mains isolating switch. Pump should start immediately. Do not run pump at wide open discharge in test tank. Throttle pump down with a gate valve.
7. As soon as the unit is running, line current reading should be taken and matched against those in the Cable Selection Table. Run the pump only a few minutes in the test tank. Stop. After one minute, start pump again.
8. If pump operates satisfactorily, turn off power at the mains isolation switch. Disconnect power supply from the control box and the control cable.
9. Replace the pump in the shipping carton to protect it during transportation to the bore site.

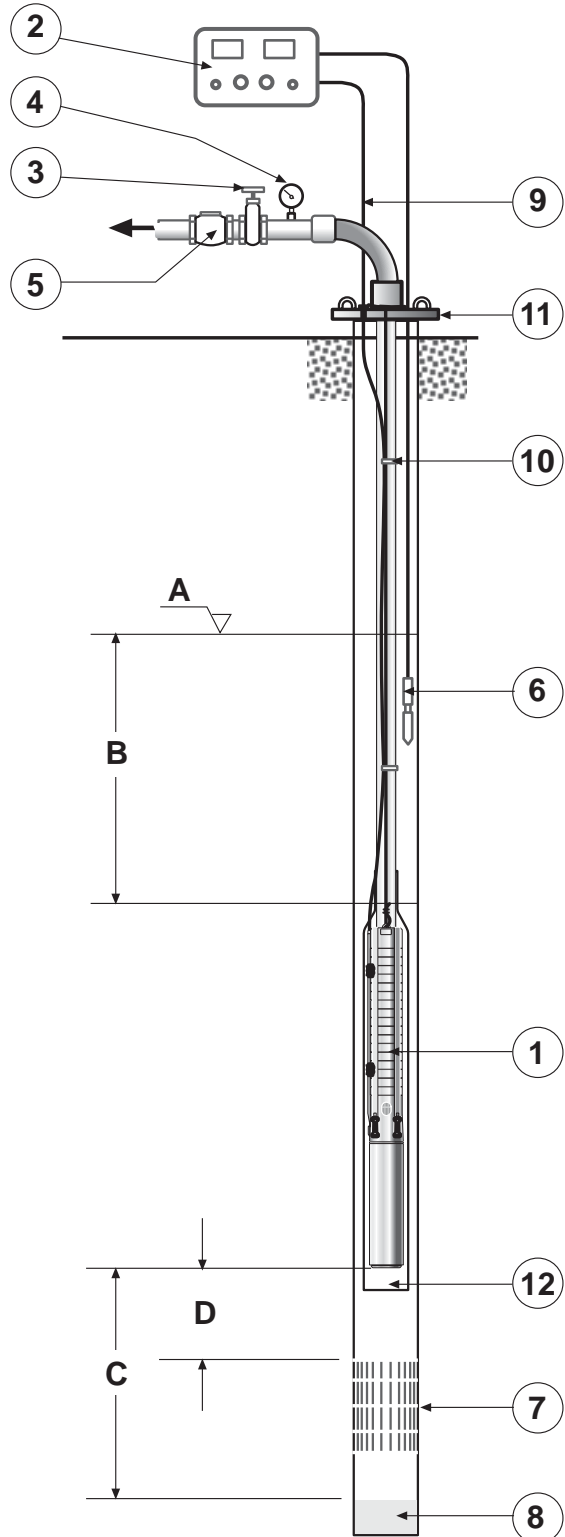

- | | | | |
|----|-------------------|----|----------------|
| 1 | Submersible Pump | 2 | Control Panel |
| 3 | Gate Valve | 4 | Pressure Gauge |
| 5 | Non-return Valve | 6 | Cut-off Device |
| 7 | Bore Screen | 8 | Bottom of Bore |
| 9 | Submersible Cable | 10 | Cable Clips |
| 11 | Bore Cap | 12 | Cooling Shroud |

- A. Water Level
- B. Distance between Water Level & Pump Outlet - Min. 4.5 metres
- C. Distance from Bottom of Bore to Bottom of Motor - Min. 3 metres
- D. Distance between Motor and Bore Screen (if applic.) - Min. 1 metre

Installation in the Bore

1. Recheck the system's electrical ratings. If the cable has been spliced, make certain that the colour code has been followed.
2. If there is a possibility the water level will drop enough to let air into the pump, a low water level electrode protective relay must be fitted to the starter. This can be either a manual reset type (only two electrodes required) or an automatic reset type (three electrodes required).
3. Attach first section of pipe to pump and tighten. If plastic riser is being used, nylon or stainless steel safety cable **must** be attached to support the pump.
4. Connect a pipe vice or collar clamp firmly to the upper end of the pipe to keep it from slipping and dropping into the bore. Lower the pipe column into the bore. Do not lower the unit by its electric cable. A nylon or stainless steel safety rope may be attached to the pump to aid in lowering it. **NOTE:** Where the riser pipe exceeds 100 metres, a non-return valve should be installed to limit damage caused by water hammer. This extra valve should be positioned halfway up the riser pipe, and must always be incorporated if the pump is being used to supply a pressurised system.
5. Lower the pipe into the well as each section is added. Make sure that the pump is installed at least 3 metres (10 feet) above the bottom of the bore to prevent sediment from covering the motor. **NOTE:** Motor must be set above level at which water enters the bore, or above bottom of casing or top of bore screen. If this is not possible, a “cooling shroud” must be used. Tape or clamp the electrical cable to the pipe at 3 metre (10 feet) intervals, being careful not to cut the insulation. The cable can be checked for insulation breaks as it is attached to the pipe. Any damaged spots should be cleaned carefully and repaired using self-amalgamating waterproof tape or adhesive lined heatshrink tubing. Do not drag cable over the bore casing or allow it to become pinched. At the top of the last length of pipe, install a tee, which can be used for lifting when adjusting the bore seal and when making final adjustment of the pump setting. A hose cock can be installed temporarily for testing bore and pump capacity.

NOTE: For the motor to function correctly, a specific minimum flow speed of water over the outside of the motor is necessary. (Refer to graph on page 8).

Wiring the Pump - Single Phase

All electrical connections must be performed by qualified personnel working in accordance with National and Local Electrical Codes.

a. Three wire installation for FRANKLIN 0.75kW motor and 1.5kW PSC motor.

1. Make sure power is off at Mains Isolation Switch.
2. Connect the colour coded drop cable to the control box terminals, making sure the WHITE wire is connected to the terminal marked "BLK" (Start), the RED wire to the terminal marked "BRN" (Common), and the BLUE wire to the terminal marked "BLU" (Main).
3. If using an Automatic Control Switch (eg. Pressure Switch), connect the leads from the L and N terminals in the control box to the Load side of the Automatic Control Switch, and then connect the leads from the Line side of the Automatic Control Switch to the two terminals in the Mains Isolation Switch.
4. If not using an Automatic Control Switch, connect the leads from the L and N terminals to the two terminals in the Mains Isolation Switch.
5. Connect Ground Wire from Control Box and motor drop cable to Steel Bore Casing or steel ground stake.
6. Replace cover on the Control Box.

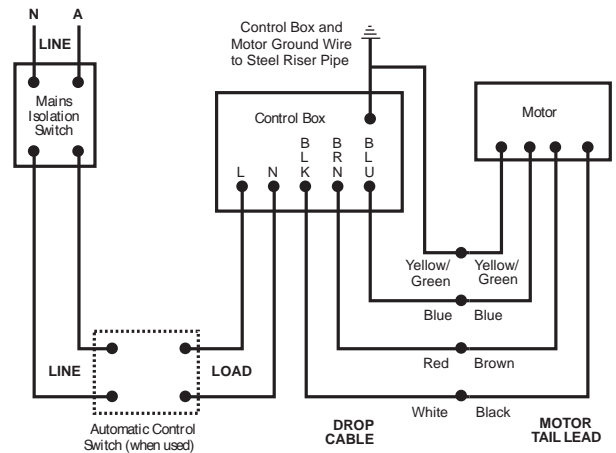

b. Three wire installation for FRANKLIN 1.1kW, 1.5kW, 2.2kW and 3.7kW motors.

1. Make sure power is off at Mains Isolation Switch.
2. Connect the colour coded drop cable to the control box terminals, making sure the WHITE wire is connected to the terminal marked "BLK" (Start), the RED wire to the terminal marked "BRN" (Common), and the BLUE wire to the terminal marked "BLU" (Main).
3. If using an Automatic Control Switch (eg. Pressure Switch), connect the leads from the L and N terminals in the control box to the Load side of the Automatic Control Switch, and then connect the leads from the Line side of the Automatic Control Switch to the two terminals in the Mains Isolation Switch.
4. If not using an Automatic Control Switch, connect the leads from the L and N terminals to the two terminals in the Mains Isolation Switch.
5. Connect Ground Wire from Control Box and motor drop cable to Steel Bore Casing or steel ground stake.
6. Replace cover on the Control Box.

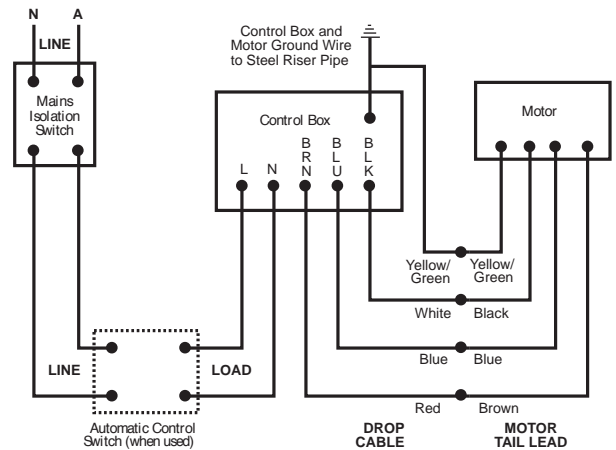

c. Two wire installation for FRANKLIN 0.37kW, 0.55kW, 0.75kW and 1.1kW motors.

1. Make sure power is off at Mains Isolation Switch.
2. If using an Automatic Control Switch (eg. Pressure Switch), connect the two leads from the motor drop cable to the Load side of the Automatic Control Switch, and then connect the leads from the Line side of the Automatic Control Switch to the two terminals in the Mains Isolation Switch.
3. If not using an Automatic Control Switch, connect the two leads from the motor cable to the two terminals in the Mains Isolation Switch.
4. Connect Ground Wire from motor drop cable to Steel Bore Casing or steel ground stake .

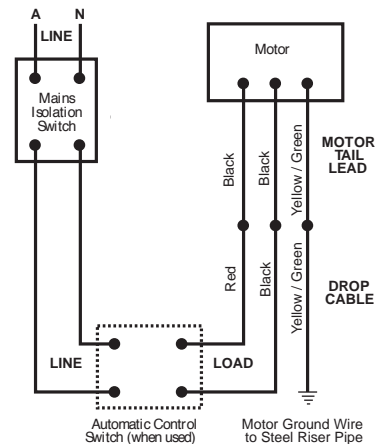

d. Overload Protection for FRANKLIN Two and Three Wire Single Phase Motors

1. Two wire motors (0.37 kW to 1.1 kW) have inbuilt automatically resetting overload protection in the motor.
2. Three wire motors (0.75 kW to 3.7 kW) have manual reset overload protection built into the correct Franklin Control Box.

Wiring the Pump - Single Phase

e. Three wire installation for COVERCO 0.37kW, 0.55kW, 0.75kW, 1.1kW, 1.5kW, 2.2kW, and 3.7kW motors. (CURRENT MODELS)

1. Make sure power is off at Mains Isolation Switch.
2. Connect the colour coded drop cable to the control box terminals, making sure the RED wire is connected to the terminal marked "6" (Start), the WHITE wire to the terminal marked "4" (Common), and the BLUE wire to the terminal marked "5" (Main).
3. If using an Automatic Control Switch (eg. Pressure Switch), connect the leads from the L and N terminals in the control box to the Load side of the Automatic Control Switch, and then connect the leads from the Line side of the Automatic Control Switch to the two terminals in the Mains Isolation Switch.
4. If not using an Automatic Control Switch, connect the leads from the L and N terminals to the two terminals in the Mains Isolation Switch.
5. Connect Ground Wire from Control Box and motor drop cable to Steel Well Casing or steel ground stake.
6. Replace cover on the Control Box.

All electrical connections must be performed by qualified personnel working in accordance with National and Local Electrical Codes.

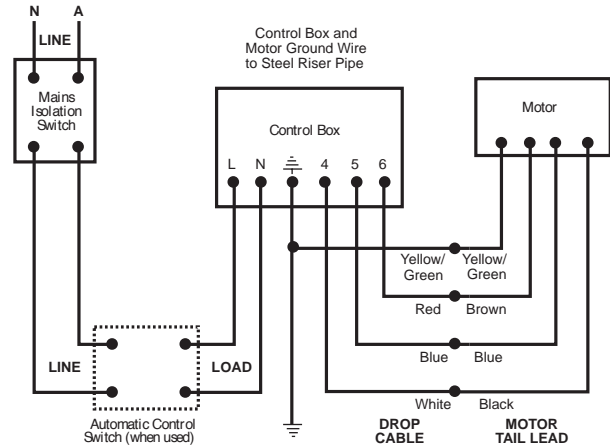

f. Three wire installation for COVERCO 1.5kW, 2.2kW and 3.7kW motors (OLDER MODELS ONLY).

1. Make sure power is off at Mains Isolation Switch.
2. Connect the colour coded drop cable to the control box terminals, making sure the RED wire is connected to the terminal marked "5" (Start), the WHITE wire to the terminal marked "3" (Common), and the BLUE wire to the terminal marked "4" (Main).
3. If using an Automatic Control Switch (eg. Pressure Switch), connect the leads from the L and N terminals in the control box to the Load side of the Automatic Control Switch, and then connect the leads from the Line side of the Automatic Control Switch to the two terminals in the Mains Isolation Switch.
4. If not using an Automatic Control Switch, connect the leads from the L and N terminals to the two terminals in the Mains Isolation Switch.
5. Connect Ground Wire from Control Box and motor drop cable to Steel Well Casing or steel ground stake.
6. Replace cover on the Control Box.

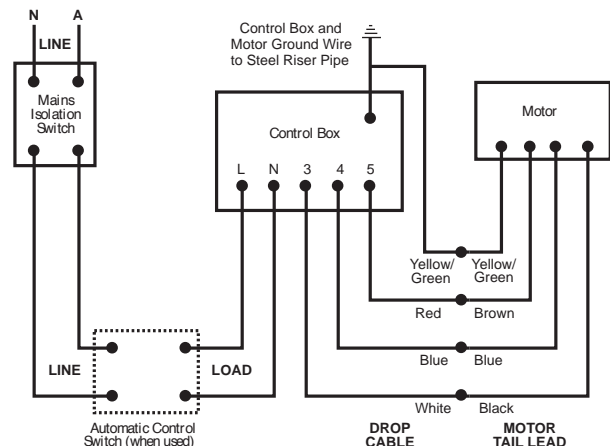

Wiring the Pump - Three Phase

Three wire installation.

1. Make sure the power is turned off at Mains Isolation Switch.
2. Connect the three wires of the motor drop cable to the LOAD terminals in the magnetic starter.
3. The Automatic Control Switch - ie. Pressure Switch, (if used), will be wired to the Magnetic Starter to serve as a pilot control. See instructions with the magnetic starter. Use correct size quick trip thermal overloads.
4. Connect three leads from the LINE terminals of the three pole magnetic starter to the fused disconnect switch. Be sure correct size fuses are used to give proper motor protection.
5. Properly grounded lightning arrestors are RECOMMENDED.
6. When power is applied, check for correct rotation. If motor is running in the wrong direction, the pump capacity will be below rated capacity. With the pump in the bore, rotation can be checked one of two ways:

All electrical connections must be performed by qualified personnel working in accordance with National and Local Electrical Codes.

- a: Discharge method - Connect the leads to the magnetic starter as in Step 2. Run the pump open discharge. Change any two leads and run the pump at open discharge again. The larger quantity of water indicates the correct rotation.
 - b: Pressure method - Connect the leads to the magnetic starter as in Step 2. Run unit with closed discharge and note the maximum pressure reading. Change any two leads and run pump with closed discharge again. Note maximum pressure reading. The higher pressure reading indicates the correct rotation.
7. After the pump has been installed and run, subsequent electrical work near the installation may change the rotation. Whenever a three phase pump does not seem to be performing properly, the rotation should be checked before the unit is pulled.

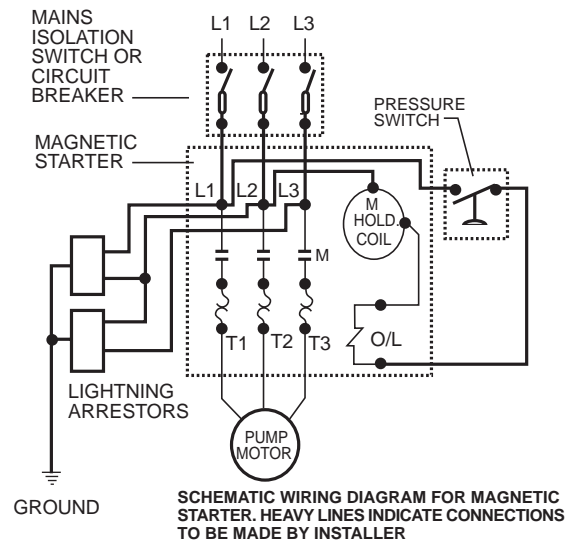

Lightning Arrestors

It is highly recommended that lightning arrestors be installed in the starter or control box to ground voltage surges. Lightning arrestors should be grounded to metal riser pipe with ground clamp, or to other suitable ground if plastic drop pipe is used. All single phase Franklin motors have built-in lightning protection and do not need an additional arrestor. Three phase units require two arrestors, and should be connected to the control as shown at right.

If a lightning arrestor has already been installed at the lead-in power lines and is within 15 metres (50 feet) of the pump installation, additional arrestors are not necessary. Arrestors should be installed at the control on overhead supply lines longer than 15 metres (50 feet). If the supply line to the control is underground, an arrestor is not needed at the control.

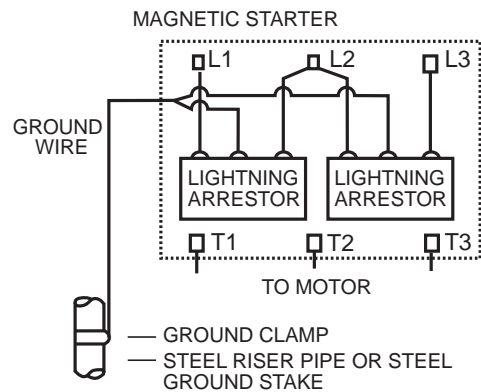

System Connections & Operation

1. Thread the cable through the hole in the bore cap. Be careful not to let the cable become pinched or damaged. Make certain the bore cap is vented. Ample slack should be left in the cable below the bore cap and in the trench (if the cable is buried underground) to allow for expansion and contraction.
2. Install a shut-off (gate) valve and a union to facilitate installation and servicing. Use of a gate valve also permits throttling for a weak supply.
3. Start the pump with the gate valve slightly open. If rotation is incorrect, the gauge will show the pressure much lower than it should be. A single phase motor always rotates in the correct direction. To reverse rotation in a 3-phase motor, swap over two of the phase wires.
4. Do not let the pump run in the wrong direction for more than 4 minutes. With the pump working, gradually open the delivery gate valve using an ammeter to check the current does not exceed that shown on the plate. If necessary, lower the amps by reducing delivery through the gate valve and adjusting the protection relay settings accordingly. The overload settings should never exceed the those on the plate.
5. With the motor running, check that the power supply voltage is $\pm 5\%$ of the nominal supply.

Final Checks

1. Make certain all connections are properly made.
2. Turn on current at mains isolation switch. Pump should start and water should flow within a few seconds, depending on depth of setting of pump.
3. Check the amperage with an ammeter and the voltage with a voltmeter. Compare the readings with pre-installation tests and limits shown in Cable Selection Table.
4. It is also recommended that a resistance reading be made. Power supply must be disconnected to make resistance readings. These tests will determine if there is damage to the cable when installing or if motor windings are down to earth.
5. Also check line voltage at the control box or magnetic starter during start and run conditions.



CABLE SELECTION OVERLOAD PROTECTION

FRANKLIN MOTOR DATA

CABLE SELECTION 4 INCH FRANKLIN SUBMERSIBLE MOTORS

SINGLE PHASE MOTOR - Maximum cable length metres (Motor to service entrance).

2 Wire motors - Cable spec – 2 core with earth, P.V.C. insulated, P.V.C. sheathed, copper conductors.

Motor kW	F.L.A.	CABLE SIZE SQ.MM						
		1.5mm ²	2.5mm ²	4mm ²	6mm ²	10mm ²	16mm ²	25mm ²
0.37 kW	4.1	101	170	267	400	670	—	—
0.55 kW	6.5	63	106	167	245	420	660	—
0.75 kW	7.6	53	89	140	210	350	560	960
1.1 kW	10.8	38	63	100	150	250	400	680

SINGLE PHASE MOTOR - Maximum cable length metres (Motor to service entrance)

3 wire motor - Cable spec – 3 core with earth, P.V.C. insulated, P.V.C. sheathed, copper conductors.

Motor kW	F.L.A.	CABLE SIZE SQ.MM						
		1.5mm ²	2.5mm ²	4mm ²	6mm ²	10mm ²	16mm ²	25mm ²
0.75kW	7.0	52	86	135	200	340	540	930
1.1 kW	8.9	38	64	100	150	250	400	690
1.5 kW	10.7	35	58	92	135	230	360	630
2.2 kW	15.9	—	37	59	89	150	230	400
3.7 kW	23.4	—	—	41	61	100	160	280

THREE PHASE MOTOR - Maximum cable length metres (Motor to service entrance)

Cable spec - 3 core with earth, P.V.C. insulated, P.V.C sheathed, copper conductors.

Motor kW	F.L.A.	CABLE SIZE SQ.MM						
		1.5mm ²	2.5mm ²	4mm ²	6mm ²	10mm ²	16mm ²	25mm ²
0.37 kW	1.1	680	1150	1810	2710	4570	—	—
0.55 kW	1.5	480	810	1280	1910	3220	5120	—
0.75 kW	2	370	620	980	1480	2490	3960	6680
1.1 kW	3	260	440	700	1050	1770	2810	4740
1.5 kW	4	200	330	530	790	1330	2120	3580
2.2 kW	6	140	230	360	550	930	1470	2490
3.0 kW	7.3	100	170	270	410	700	1110	1880
3.7 kW	9	90	150	230	350	600	950	1610
4.0 kW	10.4	80	130	210	320	540	870	1470
5.5 kW	13	60	100	150	230	400	630	1070
7.5 kW	18.7	—	70	110	170	290	470	790

OVERLOAD PROTECTION OF 4 INCH FRANKLIN SUBMERSIBLE MOTORS

SINGLE PHASE MOTORS - Single phase 0.37kW to 1.1kW (2 wire motors) have an inbuilt overload protector in the motor. Single phase 0.75kW to 3.7kW (3 wire motors) must use the correct Franklin Control Box which includes overload protection.

THREE PHASE MOTORS 0.37kW TO 7.5kW - When using three phase motors, the installing electrician must provide for Heinemann CF3 circuit breaker or ambient temperature compensated overload relays to the setting shown below.

MOTOR kW	HEINEMANN CF3 CURVE 2	ADJUSTABLE OVERLOAD RELAYS	
		NORMAL SET	MAX SET
0.37 kW	1.3 amps	1.12	1.2
0.55 kW	1.8 amps	1.58	1.7
0.75 kW	2.4 amps	2.05	2.2
1.1 kW	3.3 amps	2.88	3.1
1.5 kW	4.4 amps	3.81	4.1
2.2 kW	6.3 amps	5.49	5.9
3.0 kW	8.3 amps	7.25	7.8
3.7 kW	9.6 amps	8.46	9.1
4.0 kW	10.6 amps	9.30	10.0
5.5 kW	14.5 amps	12.74	13.7
7.5 kW	19.6 amps	17.21	18.5

**COVERCO
MOTOR DATA**

**CABLE SELECTION
OVERLOAD PROTECTION**

CABLE SELECTION 4 INCH COVERCO SUBMERSIBLE MOTORS

SINGLE PHASE MOTOR - Maximum cable length metres (Motor to service entrance)
3 Wire motors - Cable spec – 3 core with earth, P.V.C. insulated, P.V.C. sheathed, copper conductors.

Motor kW	F.L.A.	CABLE SIZE SQ.MM						
		1.5mm ²	2.5mm ²	4mm ²	6mm ²	10mm ²	16mm ²	25mm ²
0.37 kW	3.4	140	230	360	550	920	—	—
0.55 kW	4.4	100	160	260	390	670	1070	—
0.75 kW	5.6	80	130	210	310	530	850	1460
1.1 kW	8.1	58	96	150	220	380	610	1040
1.5 kW	10.1	44	73	110	170	290	460	790
2.2 kW	14.1	—	50	80	120	200	320	550
3.7 kW	23.4	—	—	45	65	110	180	300

THREE PHASE MOTOR - Maximum cable length metres (Motor to service entrance)
Cable spec - 3 core with earth, P.V.C. insulated, P.V.C sheathed, copper conductors.

Motor kW	F.L.A.	CABLE SIZE SQ.MM						
		1.5mm ²	2.5mm ²	4mm ²	6mm ²	10mm ²	16mm ²	25mm ²
0.37 kW	1.2	680	1150	1810	2710	4570	—	—
0.55 kW	1.8	450	760	1200	1810	3040	4840	—
0.75 kW	2.1	410	690	1080	1630	2740	4350	7350
1.1 kW	3	260	440	700	1050	1770	2810	4740
1.5 kW	4.5	200	340	540	810	1370	2170	3670
2.2 kW	6	150	250	390	590	990	1580	2670
3.0 kW	7.7	110	180	290	430	730	1160	1960
4.0 kW	10.3	80	130	210	320	550	880	1480
5.5 kW	13.1	60	100	160	240	400	640	1090
7.5 kW	18.7	—	70	110	170	290	470	790

OVERLOAD PROTECTION OF 4 INCH COVERCO SUBMERSIBLE MOTORS

SINGLE PHASE MOTORS - Single phase motors must use the correct Coverco Control Box which also includes overload protection.

THREE PHASE MOTORS 0.37kW TO 7.5kW - When using three phase motors, the installing electrician must provide for Heinemann CF3 circuit breaker or ambient temperature compensated overload relays to the setting shown below.

MOTOR kW	HEINEMANN CF3 CURVE 2	ADJUSTABLE OVERLOAD RELAYS	
		NORMAL SET	MAX SET
0.37 kW	1.3 amps	1.12	1.2
0.55 kW	1.9 amps	1.67	1.8
0.75 kW	2.1 amps	1.86	2.0
1.1 kW	3.3 amps	2.88	3.1
1.5 kW	4.3 amps	3.72	4.0
2.2 kW	5.8 amps	5.12	5.5
3.0 kW	8.0 amps	6.98	7.5
4.0 kW	10.5 amps	9.21	9.9
5.5 kW	14.3 amps	12.56	13.5
7.5 kW	19.6 amps	17.21	18.5



MOTOR COOLING

The following graph shows the minimum required water flow past motor for cooling. For example a 100mm (4") Franklin motor and pump installed in 200mm inside diameter bore casing requires a minimum flow past the motor of 1.9 litres per second. If minimum flow calculated from the graph is not achieved a pump shroud must be fitted to ensure adequate motor cooling.

IMPORTANT: In all cases the water must enter the casing from below the motor, or for bores fitted with perforated casing, or wells where the water enters from above the pump, a cooling shroud **MUST** be fitted to ensure cooling water continuously flows past the motor.

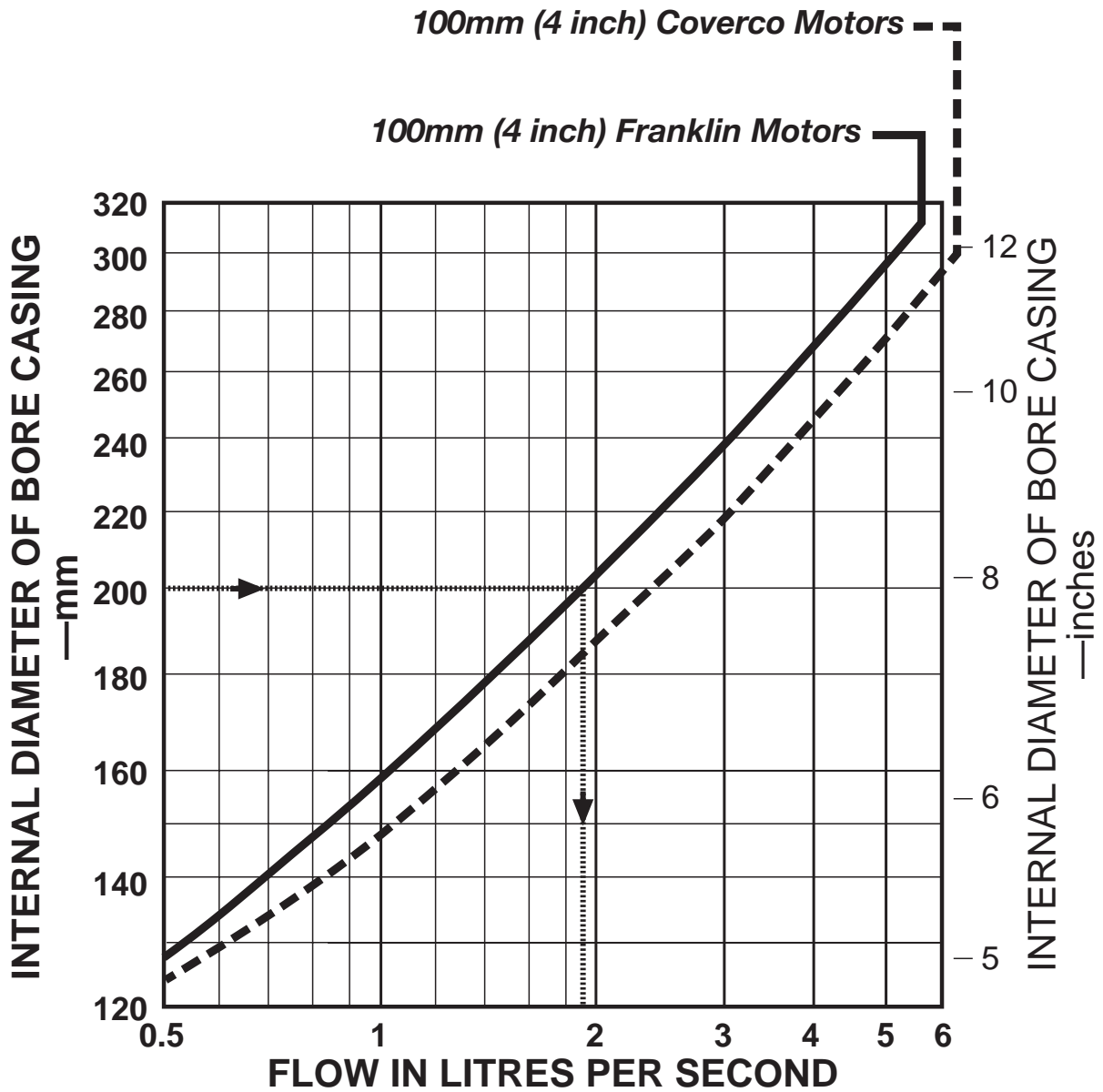



TROUBLE SHOOTING CHART

Problem	Possible Cause of Trouble & Remedy
Pump will not run.	<ol style="list-style-type: none"> 1. No power. Replace fuses or reset circuit breaker. Contact electrician if required. 2. Incorrect voltage. Contact electrician if necessary. 3. Incorrect fuses. Replace with proper fuses. 4. Defective pressure switch. Clean contact points or replace points. 5. Defective wiring. Check for loose or corroded connections. 6. Control box malfunction. Check wiring circuits and components. Correct wiring and/or replace defective components. Press prong connectors to assure contact. 7. Bound or defective pump. Sand bound three phase units can sometimes be corrected by temporarily reversing any two leads (except earth wire), running for 5 to 10 seconds, then returning to normal. Pull pump and repair if unsuccessful. 8. Defective cable or motor winding. Pump must be pulled and the motor or electrical cable repaired or replaced.
Pump runs, but delivers little or no water.	<ol style="list-style-type: none"> 1. Check valve. Reverse check valve. 2. Pump rotation wrong. For three phase units, swap any two leads (except earth wire). 3. Incorrect wiring. For three-wire single phase units, check wiring connections. 4. Leak in riser pipe. Raise pipe, check for leak and replace damaged section. 5. Pump screen blocked. Clean screen and reset at less depth. Bore may have to be cleaned. 6. Air locked pump. Normal delivery may resume if pump is started and stopped at one minute intervals. 7. Low water level. Throttle pump output or reset pump at lower depth if possible. 8. Worn pump. Pull pump and repair or replace. 9. Loose or broken motor or shaft. Check for damaged shaft if coupling is loose. Replace worn or defective unit.
Pump will not turn off. (Automatic Control)	<ol style="list-style-type: none"> 1. Pressure switch. Clean points or replace switch. 2. Low water level. Throttle pump output or reset pump at lower depth if possible. 3. Leak in system. Repair or replace tank or pipe section. 4. Worn pump. Pull pump and repair or replace.
Pump starts too often. (Automatic Control)	<ol style="list-style-type: none"> 1. Pressure switch. Reset switch limits or replace switch. 2. Check valve. Remove and replace if defective. 3. Leak in system. Repair or replace tank or pipe section. 4. Water logged tank. Clean or replace air volume control. Drain and recharge tank.

If none of the above remedies the problem please contact your local Southern Cross Dealer or call Tyco pumping Systems on 131 786

WARNINGS & SPECIFICATIONS

All electrical connections must be performed by qualified personnel working in accordance with National and Local Electrical Codes.

Check that the details on the pump's specifications plate correspond to your order.

Check that the pump has not been damaged during transit, paying particular attention to the electrical cables.

Never support the weight of the pump on the electrical cable.

Do not use these pumps in swimming pools.

Never run the pump dry - even briefly - as this will cause **serious damage**.

Only for use with chemically and physically non-aggressive water.

Maximum solid content: 25gr/m³.

Maximum temperature of liquid to be pumped: 30°C.

Maximum time for running pump with gate valve closed: 2 minutes.

Maximum number of starts (at even intervals) per hour: 20.

Maximum voltage variation to motor: ± 5% of specified voltage.



Telephone 131 786

A division of **tyco** Flow Control Pacific Pty Ltd
A.B.N. 83 000 922 690

Form 2810 July 2006